

# DIN 910

## Screw plug

with flange and external hexagon

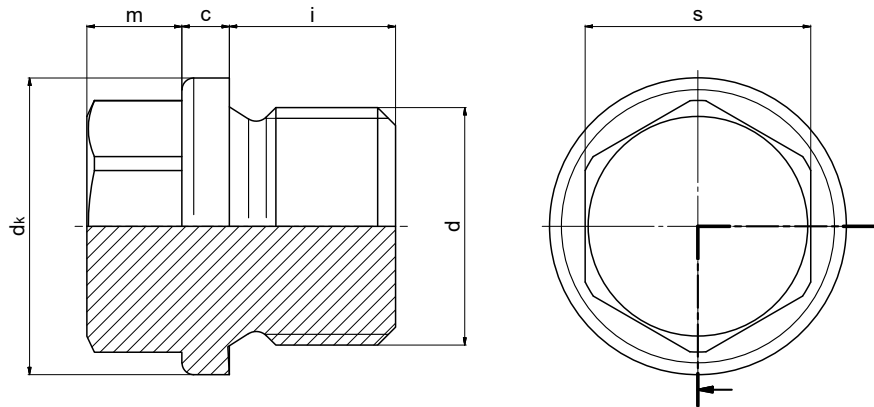

### Application areas:

- Mechanical engineering, gear manufacturing, automotive and many others
- for counter bores as per DIN 3852-1 and ISO 3852-2
- usually for use with sealing rings in acc. with DIN 7603

### Material:

- Steel 11SMnPb30+C (1.0718)  
DIN EN 10227-3 ultrasonic and crack tested or "HD-quality"
- Stainless steel 1.4305 / 1.4571
- other materials upon request

### Coating:

- Cr-(VI) free: nano passivated A3K/Zn Nano (ISO 4042)
- ZNNI as per VDA 235.104-25
- other coatings upon request

d		Pipe thread DIN EN ISO 228	c +0,5	dk h14	i ±0,2	m ±1/2 IT15	s h14	Weight ~kg per 100 pieces
Metric fine thread DIN 13								
M8 x 1*	—	—	3	12	8	5	8	0,80
M10 x 1	—	G 1/8 A	3	14	8	6	10	1,20
M12 x 1,5	—	—	3	17	12	6	13	2,03
—	—	G 1/4 A	3	18	12	6	13	2,38
M14 x 1,5	—	—	3	19	12	6	13	2,50
M16 x 1,5	—	—	3	21	12	6	17	3,52
—	—	G 3/8 A	3	22	12	6	17	3,81
M18 x 1,5	—	—	4	23	12	8	17	4,86
M20 x 1,5	M20 x 2	—	4	25	14	8	19	6,45
—	—	G 1/2 A	4	26	14	8	19	6,66
M22 x 1,5	—	—	4	27	14	8	19	7,34
—	—	G 5/8 A*	4	28	10	8	19	6,80
M24 x 1,5	—	—	4	29	14	9	22	9,35
M26 x 1,5	—	—	4	31	16	10	24	12,00
—	M27 x 2	G 3/4 A	4	32	16	10	24	12,70
M30 x 1,5	M30 x 2	—	4	36	16	10	24	14,80
—	M33 x 2	G 1 A	5	39	16	11	27	19,50
M36 x 1,5	M36 x 2	—	5	42	16	11	27	22,00
M38 x 1,5	—	G 1 1/8 A	5	44	16	11	27	23,80
—	M39 x 2	—	5	46	16	11	27	25,50
M42 x 1,5	M42 x 2	G 1 1/4 A	5	49	16	12	30	30,00
M45 x 1,5	M45 x 2	—	5	52	16	12	30	34,00
M48 x 1,5	M48 x 2	G 1 1/2 A	5	55	16	12	30	37,50
M52 x 1,5	M52 x 2	—	5	60	16	12	30	43,00
—	—	G 1 3/4 A	5	62	20	15	36	57,20
—	M56 x 2	—	5	64	20	15	36	62,00
—	M60 x 2	G 2 A	5	68	20	15	36	69,50
—	M64 x 2	—	5	72	20	15	36	77,40
—	—	G 2 1/2 A*	5	84	20	15	36	102,20

\*This thread size is not contained in DIN 910! Measurements based on DIN 910.